

stockists order form

component diagrams

assembly guide

assembly diagram

survey information

global 600

THE GUIDE

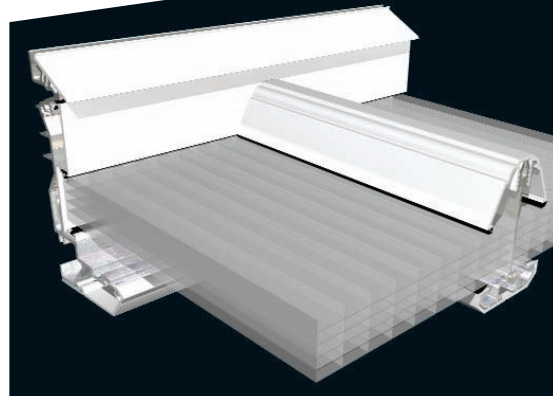
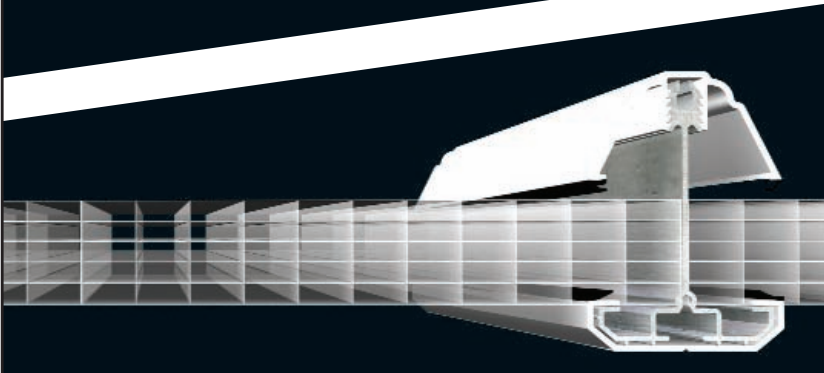

specification



survey



assembly

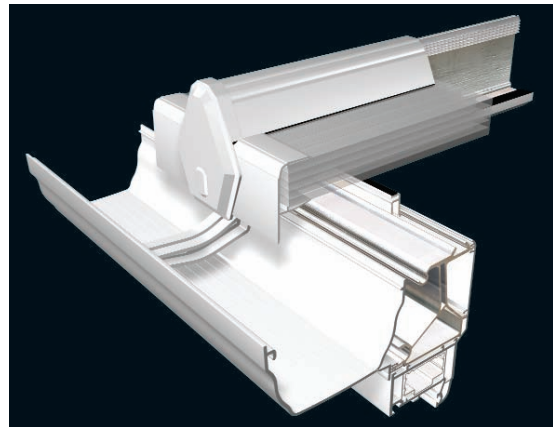

effective from October 2005

important: please read...

- Ensure you have all the relevant packages before opening them.
- Read the installation guide in this booklet prior to fitting your roof.
- Considerations should be given when constructing and installing the conservatory to:
 - “The Health and Safety at Work Act 1974”
 - “The Working at Height Regulations 2005”
 - “The Construction (Design and Management) Regulations 1994”Together with all other relevant legislation to ensure safety precautions are in place.
- Ensure the Window frames installed are done to the manufacturers recommendations and that they are square and plumb to the adjoining building.
- Ensure silicone used is “low modulus neutral cure”.

NOTE: The global 600 product has been designed to suit a 70mm Window section.

contents...

survey information **3**

assembly diagram **4**

installation guide **5**

installation guide **6**

installation guide **7**

installation guide **8**







installation guide **9**

component diagrams **10**

component diagrams **11**

stockists order form **back cover**

component colour key (used throughout the guide):

 = plastic	 = steel
 = aluminium	 = foam
 = rubber	 = various/other

survey information

WIDTH

All widths shown are internal frame sizes.

Measure distance between the internal faces of the window frames, then order roof equal to, or greater than the required size. If you order a roof larger than you require it will be necessary to modify the panel widths.

If internal frame width is greater than 6000mm you will need to order two roofs to be joined together:

E.g. To order a 8000mm wide roof, first add 600mm to the internal size required. $8000 + 600 = 8600\text{mm}$, then order a combination of roofs equal to or greater than the size required. Order two roofs 1 @ 4200mm wide and 1 @ 4800mm.

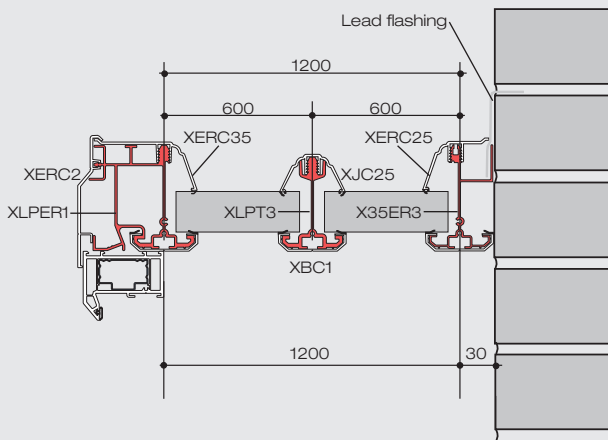
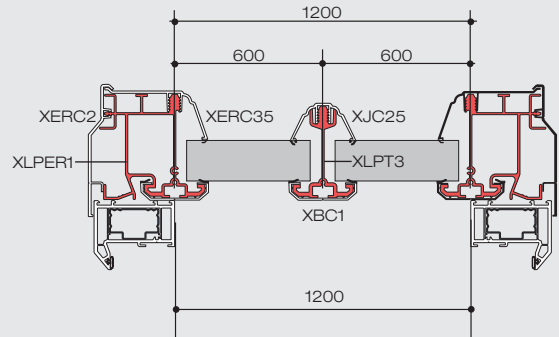

If the roof is to fit to a wall, the effective width of the roof is increased by 30mm.

E.g. a 1200mm wide roof fitted against a wall on one side will have an effective internal width of 1230mm.

PROJECTION

All projections are internal frame sizes.

Measure the distance between internal face of the window and house wall, then order the roof equal to, or greater than the required size. If you order a roof larger than you require it will be necessary to modify the panel and profile lengths.

The proposed wallplate height can be calculated using the detail below:

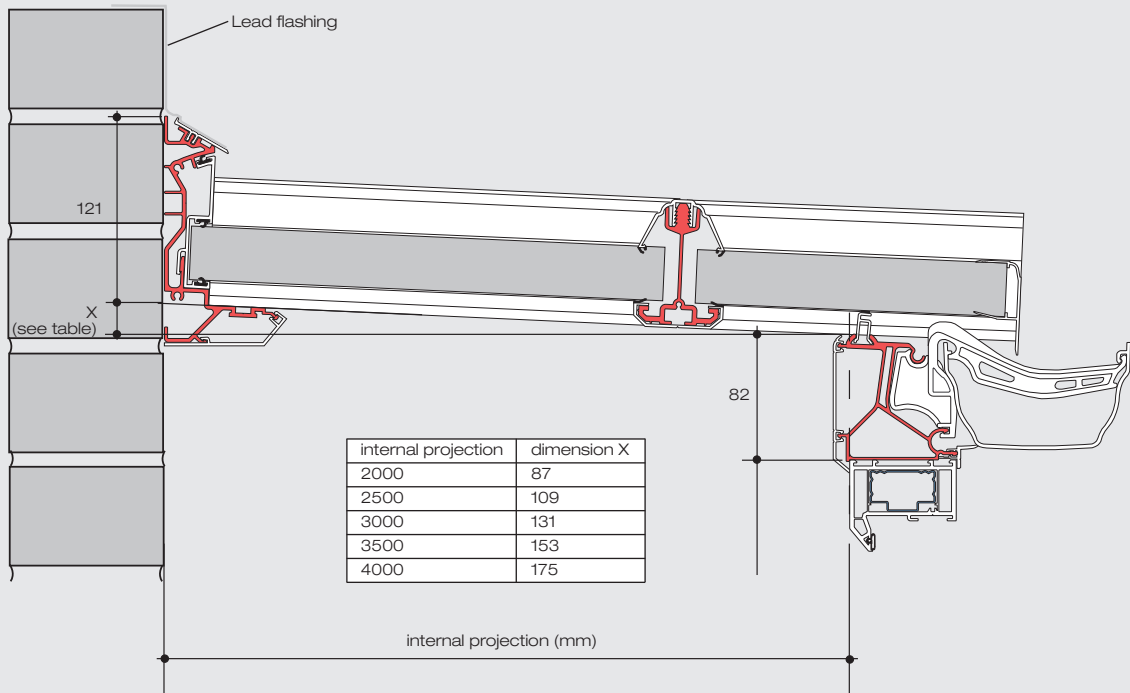

assembly diagram

the global 600 roof system

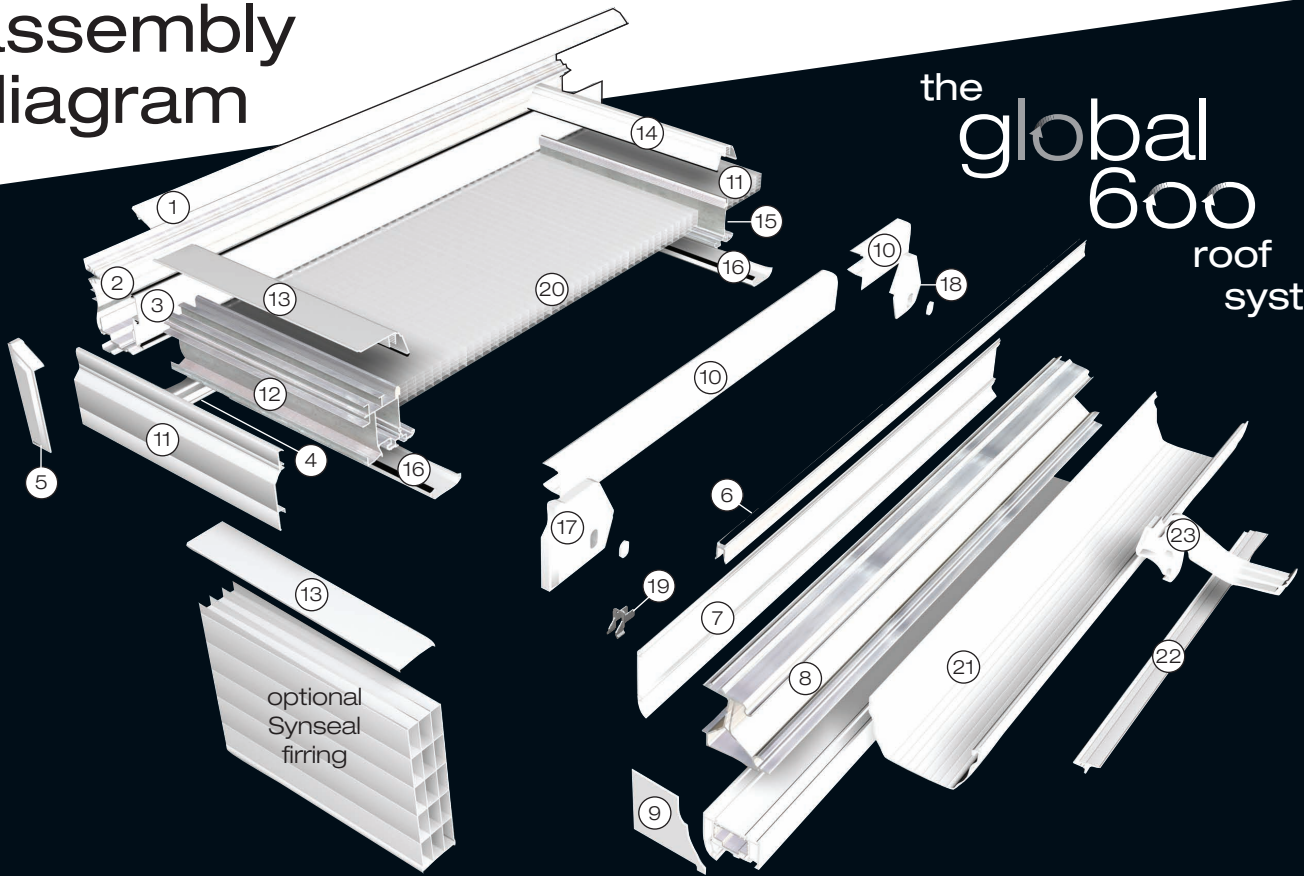

id	ITEM CODE	DESCRIPTION	G6WPE-len	G6END-len	G6GB1-len	G6GB2-len	G6PC1-len	G6PC2-len	G6NSE-len
1	XEBC5-	Wallplate Top Cap	1						
2	XLPW1-	Wallplate	1						
3	XRE35-	Rain Excluder	1						
3	XREG1	Rain Excluder Gasket	3						
4	XWPC2-	Wallplate Bottom Cap	1						
5	XLPWEC1	Wallplate End Cap (Handed)	2						
6	XPS1	Polycarbonate Support Trim	1/600mm						
7	XEBC8-	Eaves Beam Internal Cover	1						
8	XLPEB1-	Eaves Beam	1						
9	XEBC6-	Eaves Beam End Cap (Handed)	2						
10	XLPSPEC35-	Polycarbonate End Closure	1/600mm						
11	XERC2-	End Rafter Bar Side Cap		2					
12	XLPER1	End Rafter Bar for Frames		2					
13	XERC35-	End Rafter Bar for Frames Top Cap		2					
14	XJC25-	Rafter Top Cap		1	1	2			
15	XT-	Rafter		1	1	2			
16	XBC1-	Rafter Bottom Cap		3	1	2			1
17	XLPEC1-	End Rafter Bar for Frames End Cap (Handed)		2					
18	XJEC1	Rafter End Cap		1	2	2			
19	XPS2	Polycarbonate Support Trim Adaptor		4	2	2			
20	XPOLY35-	Polycarbonate					1	2	
	XLPB1	Low Pitch Foam Bung	2						
	XM525	End Cap to Wallplate Screw	2						
	XM825	Bar to Wallplate Fixing Nut and Bolt		6	2	4			2
	XM420	End Cap to Rafter Screw		3	1	2			1
	XPOLYTAPES	Breather and Closure Tapes For Polycarbonate					1	2	
	X35ER3-	End Rafter Bar for Wall							1
	XERC25-	End Rafter Bar for Wall Top Cap							1
	XWEC1-	End Rafter Bar for Wall End Cap (Handed)							2

Colour codes for roof products: WHT = White W = Mahogany OAK = Light Oak CHW = Cherrywood W-WHT = Mahogany on White
 OAK-WHT = Light Oak on White CHW-WHT = Cherrywood on White i.e. XERC2OAK (for light oak)

codes	(21) XGUT2-400	(21) XGUT2-605	(22) XGIT2-400	(22) XGIT2-605	XR21	XR577	XR19	XDP1-250	XRSY2	XUGT180	XR400	XRSY1	(23) XGC4
G6GUT-400	1		1		1	2	3	1	1	2	1	1	7
G6GUT-600		1		1	1	2	3	1	1	2	1	1	10

Colour codes for gutter products, except XGC4: Y = White V = Brown L = Caramel* i.e. XYR19 (for white) *requires disclaimer
 for XGC4: No suffix = White B = Brown C = Caramel* i.e. XGC4B (for brown)

assembly guide

This guide assumes a Synseal furring is being used (optional extra)

1. ESTABLISH LENGTH OF FIRING BOX

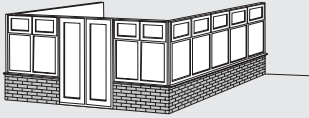

Ensure the conservatory footprint is square with the front parallel to the house wall. Measure the internal frame projection of the conservatory.

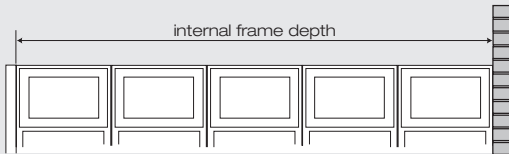

The furring box is supplied in one standard length



3. FIT FIRING BOX

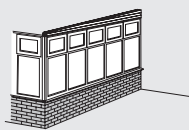

Run a silicone line along the head of the window and position the furring box. Secure the furring box using suitable fixings at 600mm maximum centres and 150mm max. in from each end. Repeat for opposite furring box.

4. ESTABLISH LENGTH OF EAVES BEAM

A. WINDOW FRAMES TO BOTH RETURNS

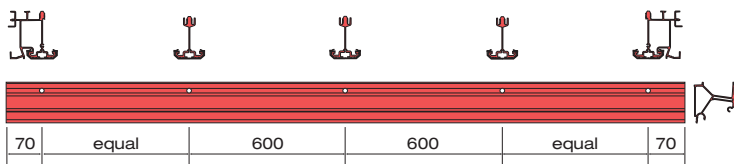

B. WALL TO ONE RETURN

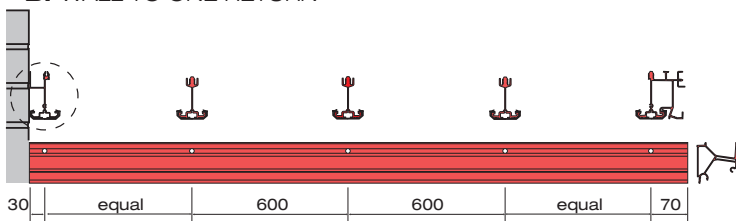

C. WALL TO BOTH RETURNS

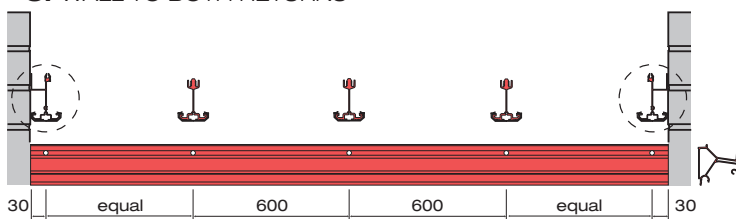

Note: the wall end rafter assembly (shown circled above) does not form part of the standard roof kit. This assembly requires ordering separately.

2. CUT DOWN AND NOTCH FIRING BOX

Transfer the internal frame size onto the furring box and cut the box to length. It is vital that you measure from the smaller end of the box!

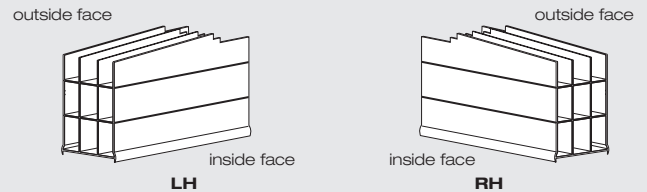
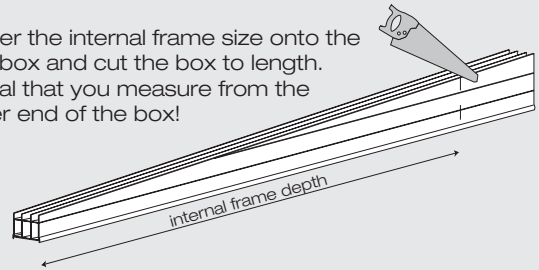

With the box cut to length, the notch details dimensioned below require cutting out of the taller end of the box. Notching is a 2 step approach as shown below.



1. Notch the other external skin of the furring box to the sizes above

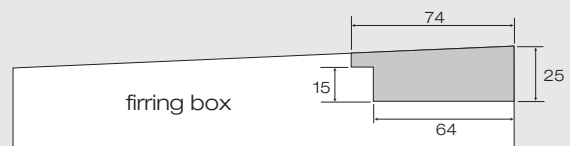

2. Notch the other 3 skins of the furring box to the sizes above

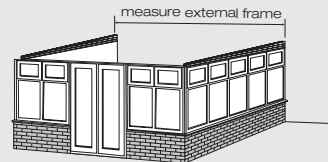

The eaves beam is supplied to suit a standard range of conservatory sizes and is prepared ready for 600mm rafter centres.

Should your conservatory be of a non-standard width, then the eaves beam will require cutting down to suit. The easiest method is to maintain a symmetrical roof by reducing the first and last rafter centres.

The 3 views shown left (A, B and C) depict the different situations that can occur.

A. Measure the length of the eaves beam provided then measure the **external** frame width. Deduct one from the other and cut half of this remaining dimension off each end of the eaves beam. Drill a new 9mm hole 70mm in from each end within the bolt slot on the eaves beam.

B. Firstly deduct 40mm from the side of the eaves beam that will go against the wall. Measure the length of remaining eaves beam then measure the **external** frame width. Deduct one from the other and cut half of this remaining dimension off each end of the eaves beam. Drill a new 9mm hole 70mm in from the frame end and 30mm in from the wall end.

C. Measure the length of the eaves beam provided then measure the distance between the walls. Deduct one from the other and cut half of this remaining dimension off each end of the eaves beam. Drill a new 9mm hole 30mm in from each end within the bolt slot on the eaves beam.

assembly guide

5. CUT DOWN AND PREPARE EAVES BEAM



The eaves beam assembly will require cutting down if your roof is of a non-standard width.

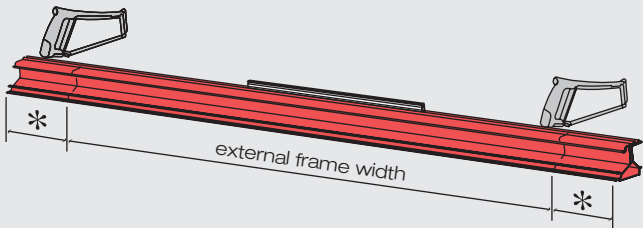

* refer to the previous instruction on how much the eaves beam length should be reduced.

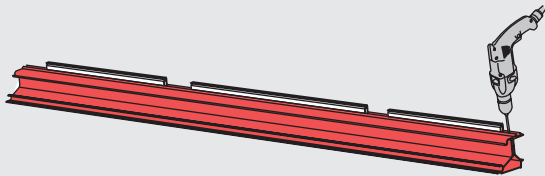

With the length of the eaves beam reduced, new end rafter fixing holes need to be drilled.

7. CUT DOWN AND PREPARE WALLPLATE

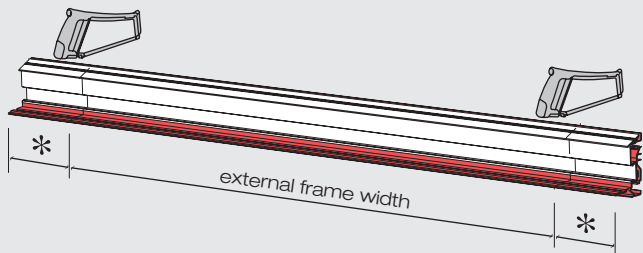

The wallplate assembly should be cut down when the conservatory width is non-standard.

* the deductions and drill hole positions should mimic the previously altered eaves beam.

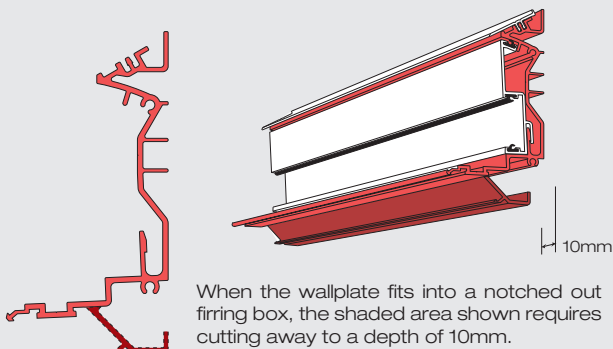
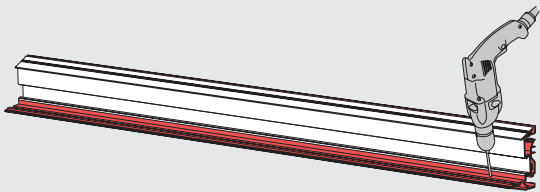

When the wallplate fits into a notched out firing box, the shaded area shown requires cutting away to a depth of 10mm.

6. FIT EAVES BEAM

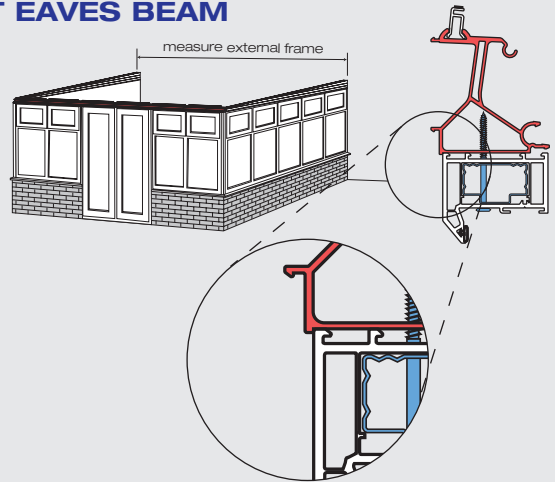

Prior to fitting the eaves beam, run a sealant line along the head of the window. Secure the eaves beam using suitable fixings at 600mm maximum centres, 150mm in from each end.

Please note the position of the eaves beam to the head of the window on the illustration above.

The eaves beam will always run over the window corner posts to external frame.

8. FIT WALLPLATE

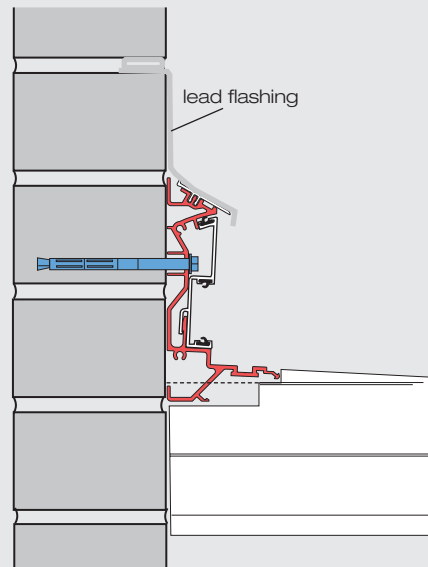

Offer the wallplate assembly to the wall so each end is resting into the notched out firings. The wallplate should be level.

Remove the rain excluder from the wallplate and secure the aluminium back to the wall with suitable fixings (600mm max. centres, 150mm max. from each end). Use the extrusion line on the aluminium as a guide for the fixing hole positions.

Refit the rain excluder.

assembly guide

9. CUT DOWN AND PREPARE RAFTERS

Establish the new rafter length, (they should all be the same if the conservatory is parallel).
Cut down the rafter and top and bottom caps to size.

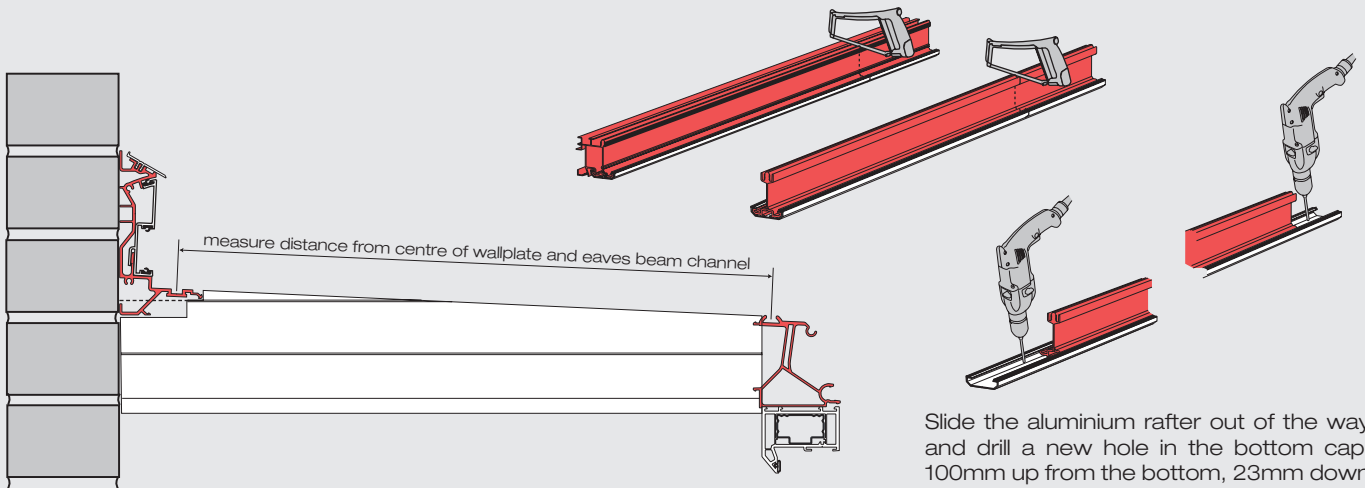

Should the projection of your conservatory be of a non-standard size, then the rafters will require cutting down in length.

To establish the new rafter length, measure the distance from the centre of the hole in the wallplate to the centre of the corresponding hole in the eaves beam, (see illustration above) and **add 123mm**. Alternatively, take the internal frame projection and add 81mm to get the rafter length.

Slide the aluminium rafter out of the way and drill a new hole in the bottom cap, 100mm up from the bottom, 23mm down from the top.

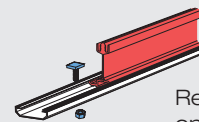

Refit the bolts to each end of the rafter

10. FIT RAFTERS

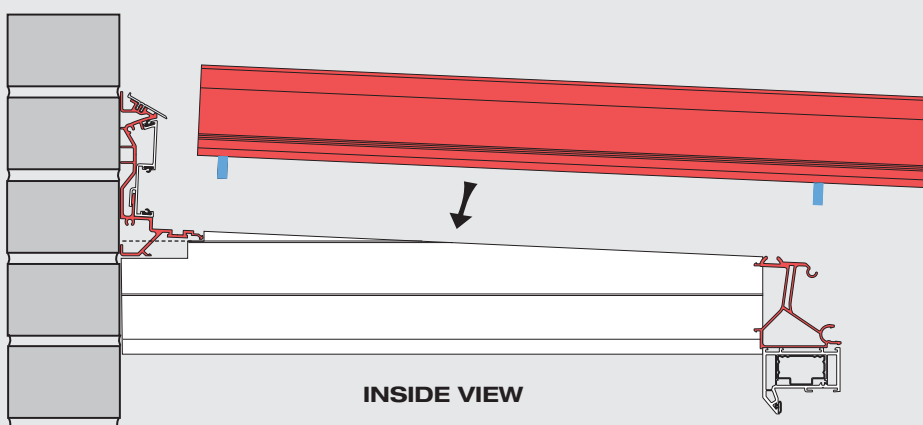

Secure the end rafter to the firing box using suitable fixings at 600mm centres, 150mm in from each end.



If the eaves beam has been cut down in length then the polycarbonate support trim will need re-cutting and fitting into the eaves beam between the rafters. Ensure that the polycarbonate support adaptors are fitted into each end of the support trim prior to fitting the rafters.

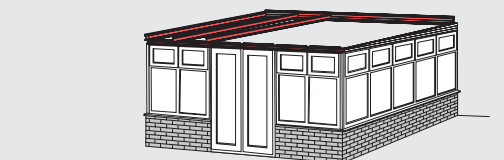
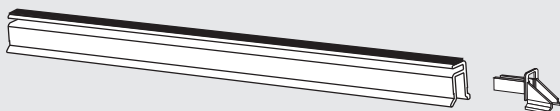

Complete the assembly of the roof skeleton

Locate each rafter into the wallplate and eaves beam holes so they span the conservatory projection.

Fasten each end with the washer headed nut provided, use a 13mm spanner.

Ensure that the aluminium rafter is flush with the rafter bottom cap before tightening.

Each rafter should be parallel with the next, square to the wallplate and eaves beam and also be at a 2.5 degree pitch.

assembly guide

11. FIT GUTTER

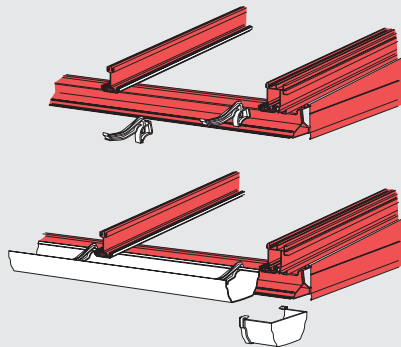

Fit the gutter brackets to the eaves beam at 600mm maximum centres, starting 200mm in from the ends. Ensure they are firmly clipped into position.

If you have cut down the length of the eaves beam, you will need to cut down the plastic gutter. (Gutter length = eaves beam length - 180mm).

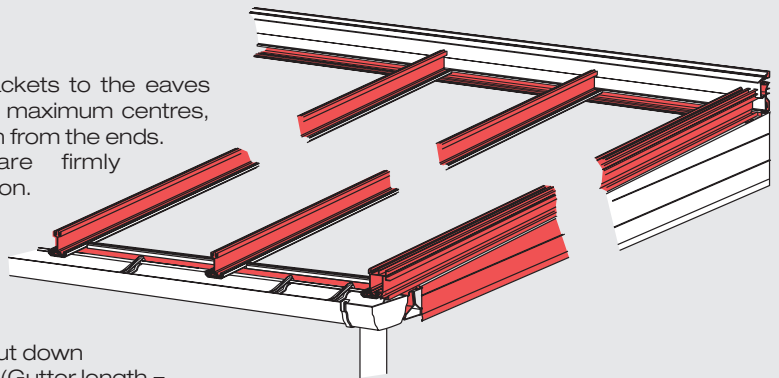

Push the gutter into the clip on the back of each bracket then pull up on the front of each bracket to locate it under the lip on the inside front of the gutter.

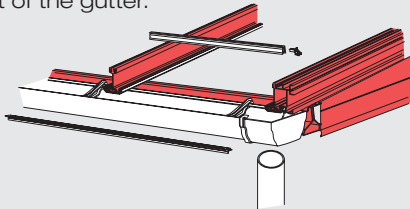

Complete the eaves beam and gutter assembly by fitting the gutter stop ends, under-gutter trim and downpipe.

If the eaves beam has been cut down in length then the polycarbonate support trim will need re-cutting and fitting into the eaves beam between the rafters. Ensure that the polycarbonate support adaptors are fitted into each end of the support trim.

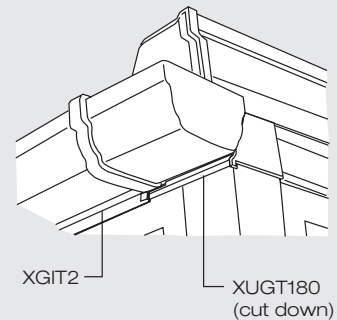

Cut down the XUGT180 to size and clip it onto the eaves beam beneath the gutter stop end.

Measure the distance between the gutter stop ends on the underside of the gutter. Cut the undergutter trim (XGIT2) to size and clip into the eaves beam.

12. PREPARE ROOF SHEETS

If the length of the rafters have been reduced to suit the size of your conservatory, the polycarbonate roof panels will need to be cut down in length by the same amount. Measure down from the end of the panel with the silver tape on. The length of the roof sheet should be rafter length +4mm.

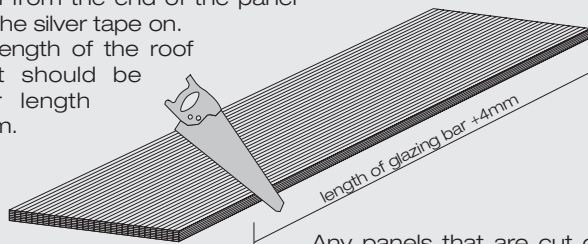

Any panels that are cut down in size will require the swarf to be vacuumed out of the chambers.

Lengths of special breather tape are supplied to close off the gutter ends of the roof panels. Ensure the protective film on the panel is pulled back prior to attaching the tapes.

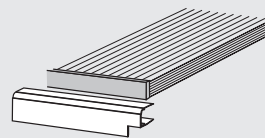
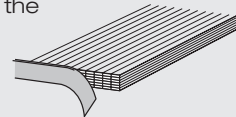

It is vital that the roof sheet end closer is sealed continually on both faces of the roof sheet.

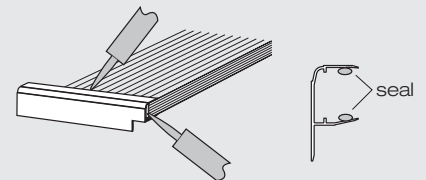

Seal closed the open cavity at each end of the sheet closer

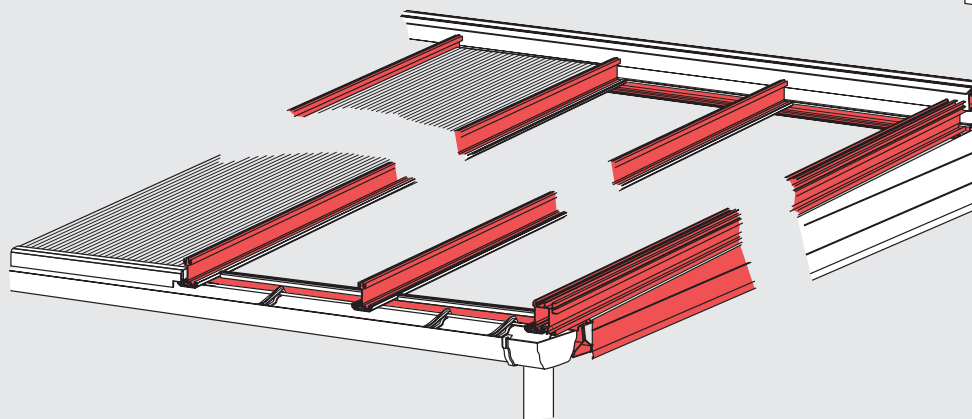

assembly guide

13. FIT ROOF SHEETS

The rafter top caps should be the same length as the rafter. Lubricate the gaskets on the caps with silicone spray or soapy water, then knock on the caps starting at the wallplate end using a white faced rubber mallet.

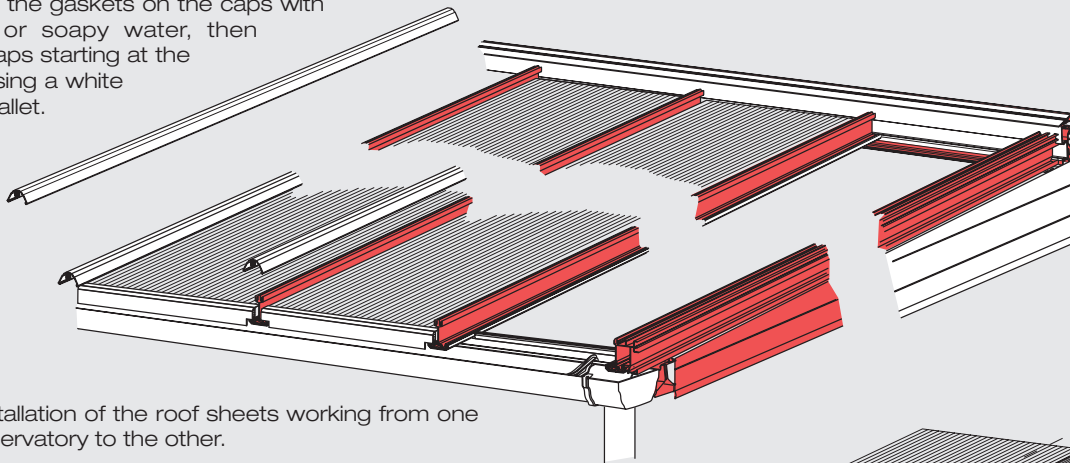

Commence installation of the roof sheets working from one end of the conservatory to the other.

Once in position, the roof sheet end closer should be flush with the end of the rafter and the panel be central between the glazing bars.

When you are happy with the position of the roof panel, lift up the panel off the support trim, remove the film from the tape and press the panel down into position.

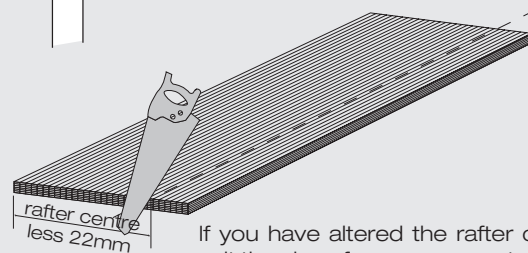

If you have altered the rafter centres to suit the size of your conservatory, you will need to cut down the width of a panel(s). The new width required will be rafter centres less 22mm (11mm each side).

14. CLOAK END RAFTER

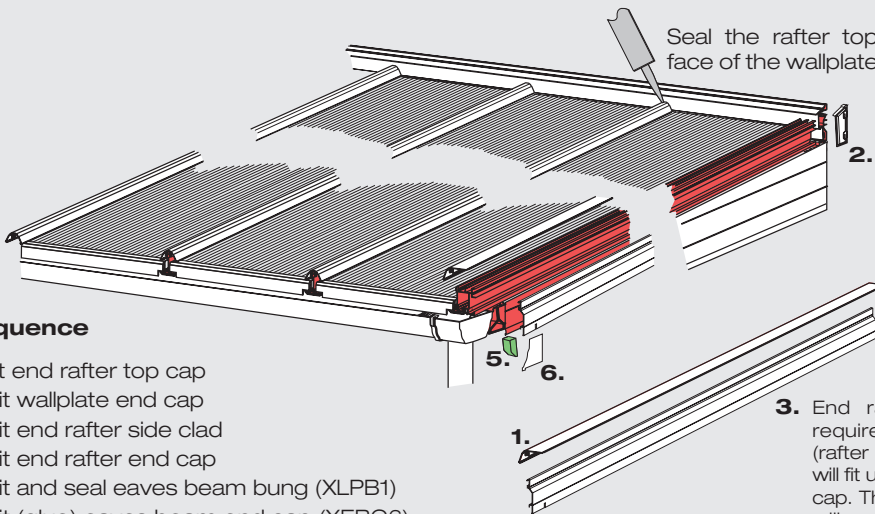

Sequence

1. Fit end rafter top cap
2. Fit wallplate end cap
3. Fit end rafter side clad
4. Fit end rafter end cap
5. Fit and seal eaves beam bung (XLPB1)
6. Fit (glue) eaves beam end cap (XEBC6)

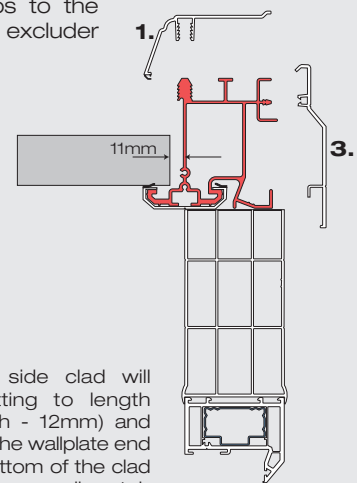

3. End rafter side clad will require cutting to length (rafter length - 12mm) and will fit up to the wallplate end cap. The bottom of the clad will require a small notch around the gutter stop end.

15. FIT REMAINING CLADDINGS AND CAPPINGS

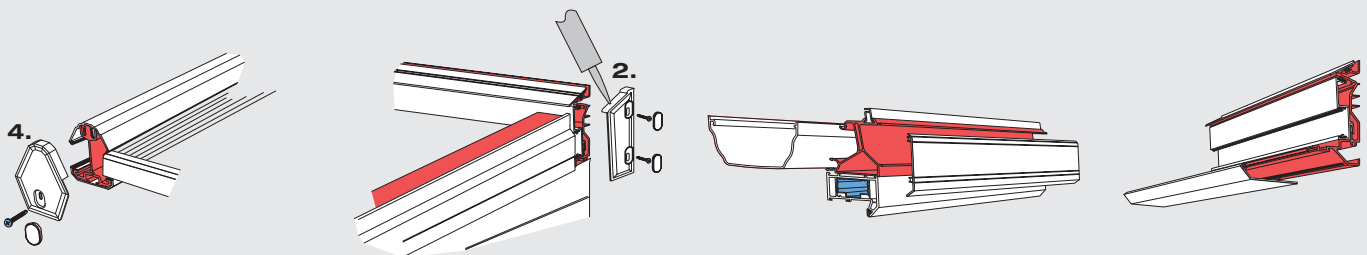

The rafter, its top and bottom cap and the roof sheet closer should be flush at the bottom. Secure the end cap with the screw provided (XM420), push on the cover cap.

Locate the wallplate end cap, ensure that the shoulder of the cap is sealed onto the wallplate top cap (see above). Secure the end cap with the machine screw provided (XM525), push on the cover cap.

Knock on the internal eaves beam cover and wallplate bottom cap using a small nylon headed hammer.

If you have altered the width of the roof, these will require cutting to size to suit the new internal frame width.

component diagrams

1 per 600mm



○ XPS1 ●●●
Polycarbonate Support Trim used on all packs

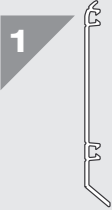

○ ●● XEBC8 ●●●
Eaves Beam Internal Cover used on all packs

2



XLPB1
Low Pitch Foam Bung used on all packs

1

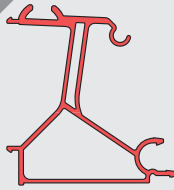

XLPEB1
Eaves Beam used on all packs

2

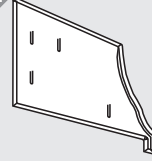

○ XEBC6L/R ●●●
Eaves Beam End Cap (Handed) used on all packs

1 per 600mm



○ XLPSP35 ●●●
Polycarbonate End Closure used on all packs

4



XM525
End Cap to Wallplate Screw used on all packs

G6WPE contents

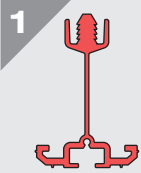

XLPT3
Transom Rafter used on 4m packs

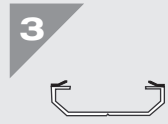

○ ●● XBC1 ●●●
Rafter Bottom Cap used on all packs

2

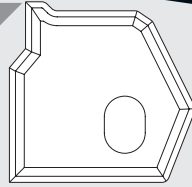

○ XLPEC1L/R ●●●
End Rafter Bar for Frames End Cap (Handed) used on all packs

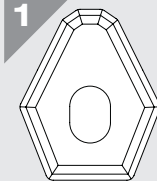

○ XJEC1 ●●●
Rafter End Cap used on all packs

4



○ XPS2 ●●●
Polycarbonate Trim Support Adaptor used on all packs



XM825
Bar to Wallplate Fixing Nut & Bolt used on all packs



XM420
End Cap to Rafter Screw used on all packs

G6WPE contents

G6WPE contents

G6END contents

G6END contents

G6END contents

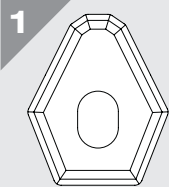

○ XJEC1 ●●●
Rafter End Cap used on all packs

2



○ XPS2 ●●●
Polycarbonate Trim Support Adaptor used on all packs

2

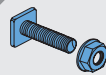

XM825
Bar to Wallplate Fixing Nut & Bolt used on all packs

1



XM420
End Cap to Rafter Screw used on all packs

1

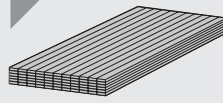

XPOLY35
Polycarbonate used on all packs

1

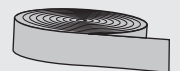

XPOLYTAPE
Breather and Closure Tapes for Polycarbonate used on all packs

G6GB1 contents

G6GB1 contents

G6PC1 contents

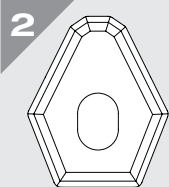

○ XJEC1 ●●●
Rafter End Cap used on all packs

4



○ XPS2 ●●●
Polycarbonate Trim Support Adaptor used on all packs

4

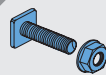

XM825
Bar to Wallplate Fixing Nut & Bolt used on all packs

2



XM420
End Cap to Rafter Screw used on all packs

2

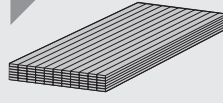

XPOLY35
Polycarbonate used on all packs

2

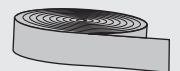

XPOLYTAPE
Breather and Closure Tapes for Polycarbonate used on all packs

G6GB2 contents

G6GB2 contents

G6PC2 contents



○ XR21 ●●●
Downpipe Shoe used on all packs

2

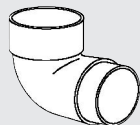

○ XR577 ●●●
92.5° Downpipe Bend used on all packs

3

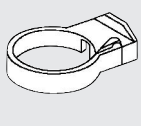

○ XR19 ●●●
Downpipe Bracket used on all packs

1

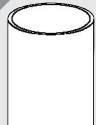

○ XDP1 ●●●
Downpipe used on all packs

2

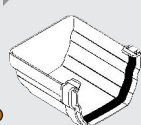

○ XRSY2 ●●●
External Stop End used on all packs

2



○ XUGT180 ●●●
180° Under Gutter Trim used on all packs

1



○ XR400 ●●●
Gutter Spigot used on all packs

1

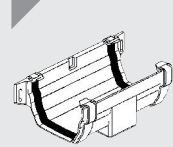

○ XRSY1 ●●●
Running Outlet used on all packs

1 per 600mm

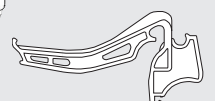

○ XGC4 ●●●
Eaves Gutter Bracket used on all packs

GUTTER

GUTTER

GUTTER

pack quantities/lengths:

These are shown in triangles such as these:

These appear above and to the left of the individual components.

stockists order form

(please photocopy and use to fax)

Account No:

Company: / /

Required delivery date: / /

White	Qty	Mahogany	Qty	Cherrywood	Qty	Light Oak	Qty	Mahogany on White*	Qty	Cherrywood on White*	Qty	Light Oak on White*	Qty
G6WPE-120		G6WPE-120W		G6WPE-120CHW		G6WPE-1200AK		G6WPE-120EXTB		G6WPE-120EXTB		G6WPE-120EXTC	
G6WPE-180		G6WPE-180W		G6WPE-180CHW		G6WPE-1800AK		G6WPE-180EXTB		G6WPE-180EXTB		G6WPE-180EXTC	
G6WPE-240		G6WPE-240W		G6WPE-240CHW		G6WPE-2400AK		G6WPE-240EXTB		G6WPE-240EXTB		G6WPE-240EXTC	
G6WPE-300		G6WPE-300W		G6WPE-300CHW		G6WPE-3000AK		G6WPE-300EXTB		G6WPE-300EXTB		G6WPE-300EXTC	
G6WPE-360		G6WPE-360W		G6WPE-360CHW		G6WPE-3600AK		G6WPE-360EXTB		G6WPE-360EXTB		G6WPE-360EXTC	
G6WPE-420		G6WPE-420W		G6WPE-420CHW		G6WPE-4200AK		G6WPE-420EXTB		G6WPE-420EXTB		G6WPE-420EXTC	
G6WPE-480		G6WPE-480W		G6WPE-480CHW		G6WPE-4800AK		G6WPE-480EXTB		G6WPE-480EXTB		G6WPE-480EXTC	
G6WPE-540		G6WPE-540W		G6WPE-540CHW		G6WPE-5400AK		G6WPE-540EXTB		G6WPE-540EXTB		G6WPE-540EXTC	
G6WPE-600		G6WPE-600W		G6WPE-600CHW		G6WPE-6000AK		G6WPE-600EXTB		G6WPE-600EXTB		G6WPE-600EXTC	
G6END-200		G6END-200W		G6END-200CHW		G6END-2000AK		G6END-200EXTW		G6END-200EXTCHW		G6END-200EXTOAK	
G6END-250		G6END-250W		G6END-250CHW		G6END-2500AK		G6END-250EXTW		G6END-250EXTCHW		G6END-250EXTOAK	
G6END-300		G6END-300W		G6END-300CHW		G6END-3000AK		G6END-300EXTW		G6END-300EXTCHW		G6END-300EXTOAK	
G6END-350		G6END-350W		G6END-350CHW		G6END-3500AK		G6END-350EXTW		G6END-350EXTCHW		G6END-350EXTOAK	
G6END-400		G6END-400W		G6END-400CHW		G6END-4000AK		G6END-400EXTW		G6END-400EXTCHW		G6END-400EXTOAK	
G6GB1-200		G6GB1-200W		G6GB1-200CHW		G6GB1-2000AK		G6GB1-200EXTW		G6GB1-200EXTCHW		G6GB1-200EXTOAK	
G6GB1-250		G6GB1-250W		G6GB1-250CHW		G6GB1-2500AK		G6GB1-250EXTW		G6GB1-250EXTCHW		G6GB1-250EXTOAK	
G6GB1-300		G6GB1-300W		G6GB1-300CHW		G6GB1-3000AK		G6GB1-300EXTW		G6GB1-300EXTCHW		G6GB1-300EXTOAK	
G6GB1-350		G6GB1-350W		G6GB1-350CHW		G6GB1-3500AK		G6GB1-350EXTW		G6GB1-350EXTCHW		G6GB1-350EXTOAK	
G6GB1-400		G6GB1-400W		G6GB1-400CHW		G6GB1-4000AK		G6GB1-400EXTW		G6GB1-400EXTCHW		G6GB1-400EXTOAK	
G6GB2-200		G6GB2-200W		G6GB2-200CHW		G6GB2-2000AK		G6GB2-200EXTW		G6GB2-200EXTCHW		G6GB2-200EXTOAK	
G6GB2-250		G6GB2-250W		G6GB2-250CHW		G6GB2-2500AK		G6GB2-250EXTW		G6GB2-250EXTCHW		G6GB2-250EXTOAK	
G6GB2-300		G6GB2-300W		G6GB2-300CHW		G6GB2-3000AK		G6GB2-300EXTW		G6GB2-300EXTCHW		G6GB2-300EXTOAK	
G6GB2-350		G6GB2-350W		G6GB2-350CHW		G6GB2-3500AK		G6GB2-350EXTW		G6GB2-350EXTCHW		G6GB2-350EXTOAK	
G6GB2-400		G6GB2-400W		G6GB2-400CHW		G6GB2-4000AK		G6GB2-400EXTW		G6GB2-400EXTCHW		G6GB2-400EXTOAK	
G6PC1-200OPL		G6PC1-200BRZ		G6PC1-200BRZ		G6PC1-200BRZ		G6PC1-200BPL		G6PC1-200BPL		G6PC1-200BPL	
G6PC1-250OPL		G6PC1-250BRZ		G6PC1-250BRZ		G6PC1-250BRZ		G6PC1-250BPL		G6PC1-250BPL		G6PC1-250BPL	
G6PC1-300OPL		G6PC1-300BRZ		G6PC1-300BRZ		G6PC1-300BRZ		G6PC1-300BPL		G6PC1-300BPL		G6PC1-300BPL	
G6PC1-350OPL		G6PC1-350BRZ		G6PC1-350BRZ		G6PC1-350BRZ		G6PC1-350BPL		G6PC1-350BPL		G6PC1-350BPL	
G6PC1-400OPL		G6PC1-400BRZ		G6PC1-400BRZ		G6PC1-400BRZ		G6PC1-400BPL		G6PC1-400BPL		G6PC1-400BPL	
G6PC2-200OPL		G6PC2-200BRZ		G6PC2-200BRZ		G6PC2-200BRZ		G6PC2-200BPL		G6PC2-200BPL		G6PC2-200BPL	
G6PC2-250OPL		G6PC2-250BRZ		G6PC2-250BRZ		G6PC2-250BRZ		G6PC2-250BPL		G6PC2-250BPL		G6PC2-250BPL	
G6PC2-300OPL		G6PC2-300BRZ		G6PC2-300BRZ		G6PC2-300BRZ		G6PC2-300BPL		G6PC2-300BPL		G6PC2-300BPL	
G6PC2-350OPL		G6PC2-350BRZ		G6PC2-350BRZ		G6PC2-350BRZ		G6PC2-350BPL		G6PC2-350BPL		G6PC2-350BPL	
G6PC2-400OPL		G6PC2-400BRZ		G6PC2-400BRZ		G6PC2-400BRZ		G6PC2-400BPL		G6PC2-400BPL		G6PC2-400BPL	
G6GUT-400		G6GUT-400B		G6GUT-400B		G6GUT-400B		G6GUT-400B		G6GUT-400B		G6GUT-400B	
G6GUT-600		G6GUT-600B		G6GUT-600B		G6GUT-600B		G6GUT-600B		G6GUT-600B		G6GUT-600B	
						G6GUT-400C#						G6GUT-400C#	
						G6GUT-600C#						G6GUT-600C#	
G6NSE-200		G6NSE-200W		G6NSE-200CHW		G6NSE-2000AK		G6NSE-200W		G6NSE-200CHW		G6NSE-200OAK	
G6NSE-250		G6NSE-250W		G6NSE-250CHW		G6NSE-2500AK		G6NSE-250W		G6NSE-250CHW		G6NSE-250OAK	
G6NSE-300		G6NSE-300W		G6NSE-300CHW		G6NSE-3000AK		G6NSE-300W		G6NSE-300CHW		G6NSE-300OAK	
G6NSE-350		G6NSE-350W		G6NSE-350CHW		G6NSE-3500AK		G6NSE-350W		G6NSE-350CHW		G6NSE-350OAK	
G6NSE-400		G6NSE-400W		G6NSE-400CHW		G6NSE-4000AK		G6NSE-400W		G6NSE-400CHW		G6NSE-400OAK	

Synseal Extrusions Limited, Common Road, Huthwaite, Sutton-in-Ashfield, Notts. NG17 6AD

TEL: (01623) 443200 FAX: (01623) 555330

www.synseal.com

global600 is a Synseal product

* When ordering a Foiled on white roof you will need to order the white roof first followed by the additional external cladding packs to suit the external colour required.

Caramel gutter may only be ordered once a colour stability disclaimer has been signed. The none standard end pack will be required should the conservatory be fixed to a house wall. Each pack contains product for 1 end only.