

Lockable Drop Down Loft Access Door

CODE **GL251-03**

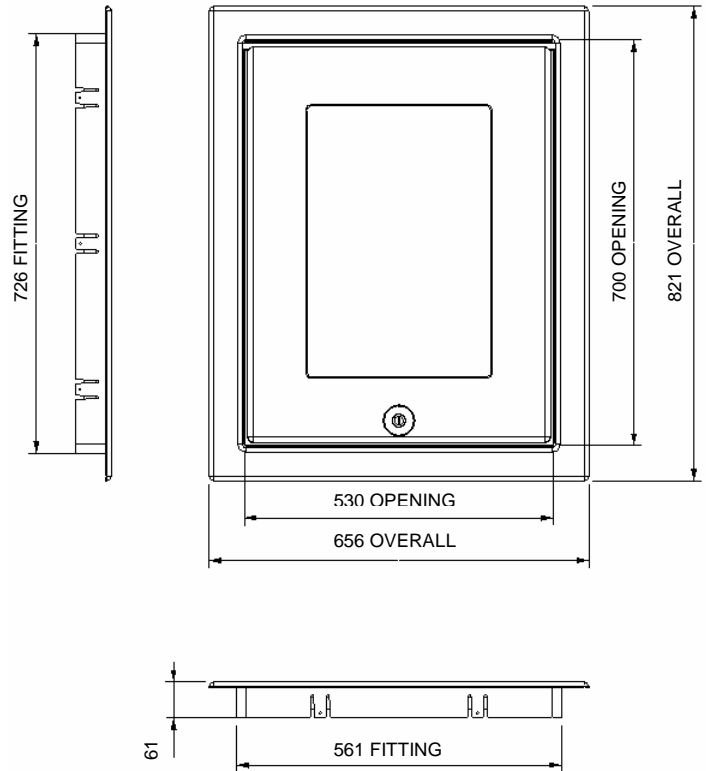
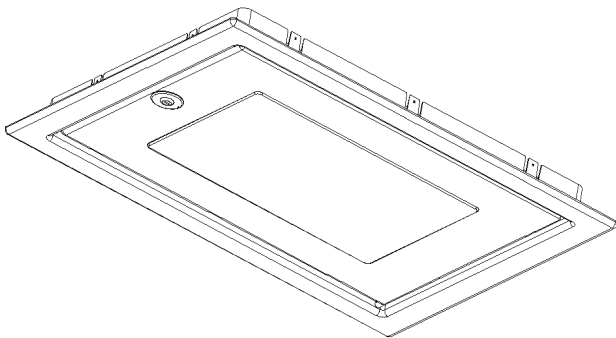

Description:

The GL251-03 Lockable Drop Down Loft Access Door is ideally suited for properties with shared accommodation to provide protection from unauthorized access in to the loft space.

The door has a lockable, three point closing mechanism along with a unique hinge system, allowing the door to be hinged down or be removed from the frame completely for unobstructed access into the roof space.

Draught seals are located to seal between both the frame and the ceiling and the door and the frame. These prevent the problem of moist warm air entering the roof space and meet the requirements of the building regulations.

The product was designed with the use of the GL256 (see Tech sheet 8187) loft ladder in mind, so as to provide safe and easy access to the roof.

As standard the door is supplied with a 50mm of EPS insulation although other insulation options are available.

The door and frame is stylish yet unobtrusive which has been designed to fit in with almost all house decor styles. With a lightly texture white finish the door can be easily cleaned with a solvent free damp cloth, or alternatively the GL251-03 can be painted to match the décor.

Environmental Assessment

Expanded Polystyrene Insulation used in the GL251/03 Has a Global Warming Potential (GWP) of less than 5 and is CFC/HCFC-free with zero Ozone Depletion Potential (ODP)

References:

BRE:	Digest 262
BSI:	BS5250
DOE:	Building Regs L1
NHBC:	Good Practice Guide
NHBC:	Standards 7.2

PACKING DETAILS	Individually Packaged in Polythene Bag and Cardboard Box.
MATERIAL	HIPS
WEIGHT	3.8Kg
SEAL	Closed Cell PVC
INSULATION	Expanded Polystyrene

MANTHORPE BUILDING PRODUCTS LTD
MANTHORPE HOUSE
BRITAIN DRIVE
CODNOR GATE BUSINESS PARK
RIPLEY
DERBYSHIRE DE5 3ND

TEL: 01773 514 200
FAX: 01773 514 262
EMAIL: sales@manthorpe.co.uk
WEB: www.manthorpe.co.uk

DRN R.P

Date 8.04.04

DRG No

Issue

The company maintains a policy of continuous development of its product range and reserves the right to amend the specification without notice.

MBP 8213

A